

6 5 4 3 2 1

D C B A

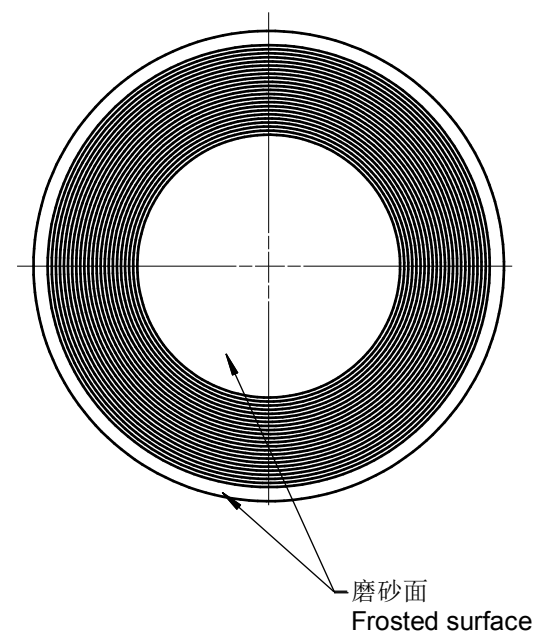
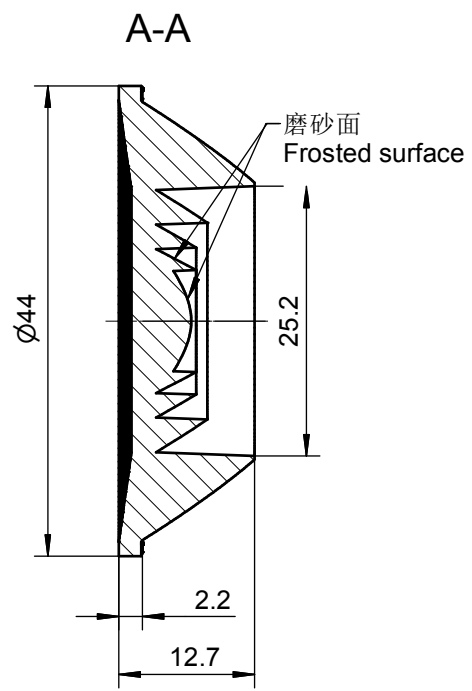
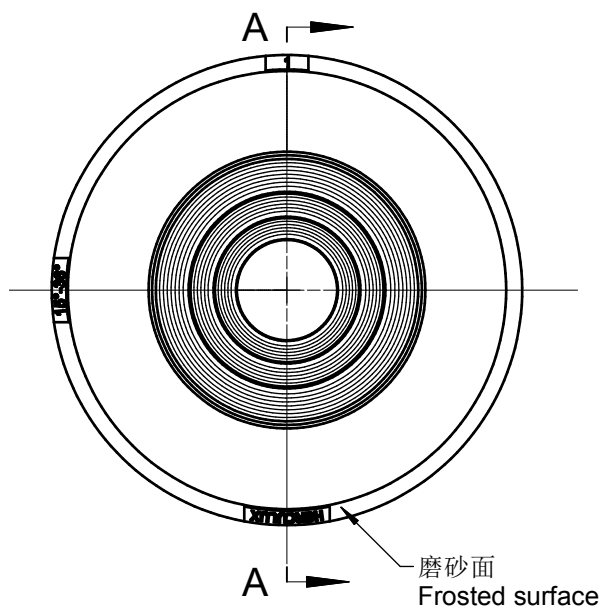

技术要求:
 1、未注圆角及拔模斜度按3D图。
 2、未注尺寸公差按右表。
 3、表面无飞边, 缩水, 气泡等缺陷。
 *4、灯具采用胶圈防水时: 要求散热器与胶圈的接触面的粗糙度: Ra<3.2μm

Technical remark:
 1.Fillet and inclination not indicated according to 3D drawing.
 2. Dimensional tolerances not indicated are shown in the right list.
 3. The surface has no flash, shrinkage, bubbles and other defects.
 *4. When the lamp adopts rubber ring for waterproofing: the roughness of the contact surface between the radiator and the rubber ring is required: Ra<3.2μm

| 基本尺寸 | 公差值 |
|------------|-----------------|
| Basic size | Tolerance value |
| <3 | ±0.1 |
| 3~10 | ±0.15 |
| 10~24 | ±0.20 |
| 24~65 | ±0.35 |
| 65~140 | ±0.50 |
| 140~250 | ±0.80 |
| 250~450 | ±1.2 |
| >450 | ±2.0 |

| 序号 | 更改标记 | 更改内容 | 更改日期 | 签名 | 序号 | 更改标记 | 更改内容 | 更改日期 | 签名 | |
|---------------------------|-------------|----------------|-------------|-----------|--|-------------|----------------|-------------|------------------------|--|
| Item | Change mark | Change content | Change date | Signature | Item | Change mark | Change content | Change date | Signature | |
| 2 | | | | | 4 | | | | | |
| 1 | | | | | 3 | | | | | |
| 光学设计 Optical design | | | | | Title: HK 44@13-变焦透镜 (15度至36度) | | | | | |
| 结构设计 Structural design | | | | | | | | | | |
| 审核 Verify | | | | | Drawing No. HK-44@13-15_36-D6-20-1g-1 | | | | | |
| 审定 Approval | | | | | | | | | | |
| | | | | 材料 | PC | | | | Part No. 1.01.91774 | |
| | | | | | | | | CDHK | | |

6 5 4 3 2 1