

LED基板上表面  
Upper surface of  
LED substrate

A-A

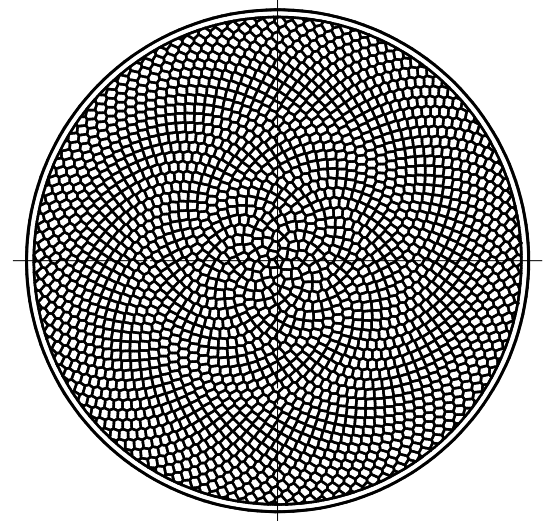
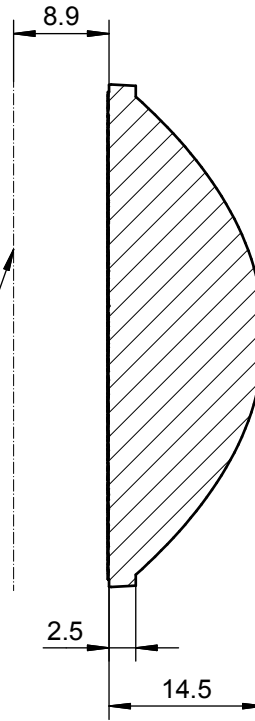

基本尺寸 Basic size	公差值 Tolerance value
<3	±0.1
3~10	±0.15
10~24	±0.20
24~65	±0.35
65~140	±0.50
140~250	±0.80
250~450	±1.2
>450	±2.0

技术要求:  
 1、未注圆角及拔模斜度按3D图。  
 2、未注尺寸公差按右表。  
 3、表面无飞边, 缩水, 气泡等缺陷。  
 \*4、灯具采用胶圈防水时: 要求散热器与胶圈的接触面的粗糙度: Ra<3.2µm。

Technical remark:  
 1.Fillet and inclination not indicated according to 3D drawing.  
 2. Dimensional tolerances not indicated are shown in the right list.  
 3. The surface has no flash, shrinkage, bubbles and other defects.  
 \*4. When the lamp adopts rubber ring for waterproofing: the roughness of the contact surface between the radiator and the rubber ring is required: Ra<3.2µm.

2					4				
1					3				
序号 Item	更改标记 Change mark	更改内容 Change content	更改日期 Change date	签名 Signature	序号 Item	更改标记 Change mark	更改内容 Change content	更改日期 Change date	签名 Signature
光学设计 Optical design			Title:			Drawing No.			
结构设计 Structural design			HK D55变焦模组透镜			HK-47@15-15_45-D9-00-1g-1			
审核 Verify						Part No.			
审定 Approval			材料 Material:	PC	1.01.13018				
					CDHK				

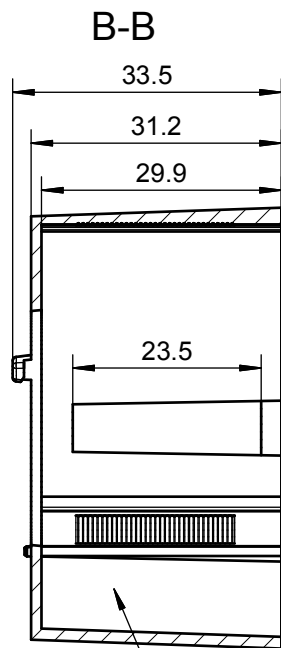
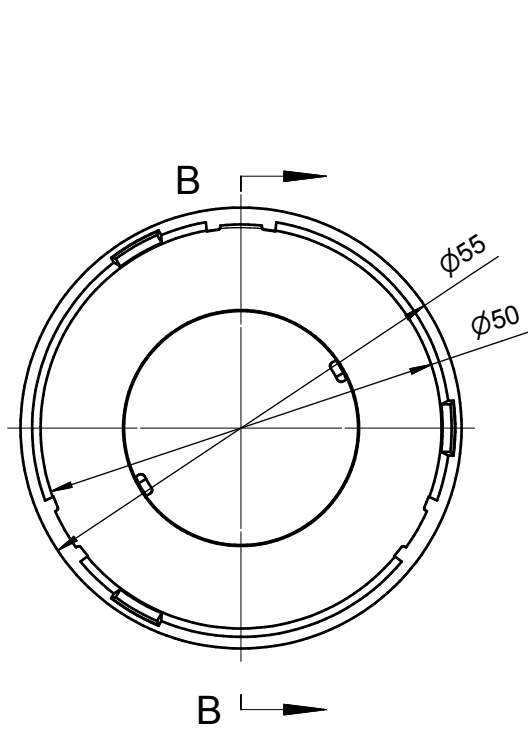

磨砂面  
Frosted surface

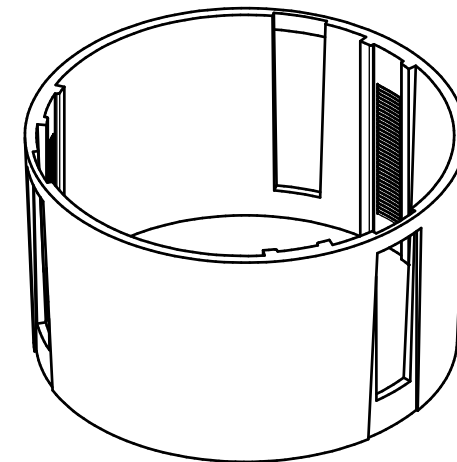
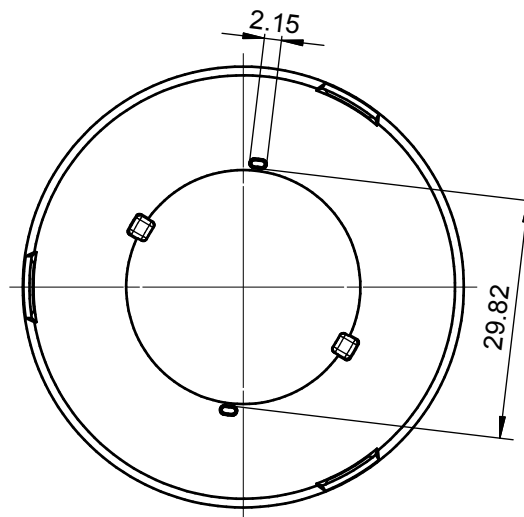

基本尺寸	公差值
Basic size	Tolerance value
<3	±0.1
3~10	±0.15
10~24	±0.20
24~65	±0.35
65~140	±0.50
140~250	±0.80
250~450	±1.2
>450	±2.0

技术要求:

- 1、未注圆角及拔模斜度按3D图。
- 2、未注尺寸公差按右表。
- 3、表面无飞边，缩水，气泡等缺陷。
- \*4、灯具采用胶圈防水时：要求散热器与胶圈的接触面的粗糙度：Ra<3.2μm。

Technical remark:

1. Fillet and inclination not indicated according to 3D drawing.
2. Dimensional tolerances not indicated are shown in the right list.
3. The surface has no flash, shrinkage, bubbles and other defects.
- \*4. When the lamp adopts rubber ring for waterproofing: the roughness of the contact surface between the radiator and the rubber ring is required: Ra<3.2μm.

2					4				
1					3				
序号 Item	更改标记 Change mark	更改内容 Change content	更改日期 Change date	签名 Signature	序号 Item	更改标记 Change mark	更改内容 Change content	更改日期 Change date	签名 Signature
光学设计 Optical design					Title:		Drawing No.		
结构设计 Structural design					HK D55变焦模组固定支架 HK D55 zoom module set fixing bracket		HK-55@34-0753-S-H		
审核 Verify							Part No.		
审定 Approval					材料 Material: PC+黑色 PC+Black		1.07.13019H		
							CDHK		

