

6 5 4 3 2 1

D

C

B

A

D

C

B

A

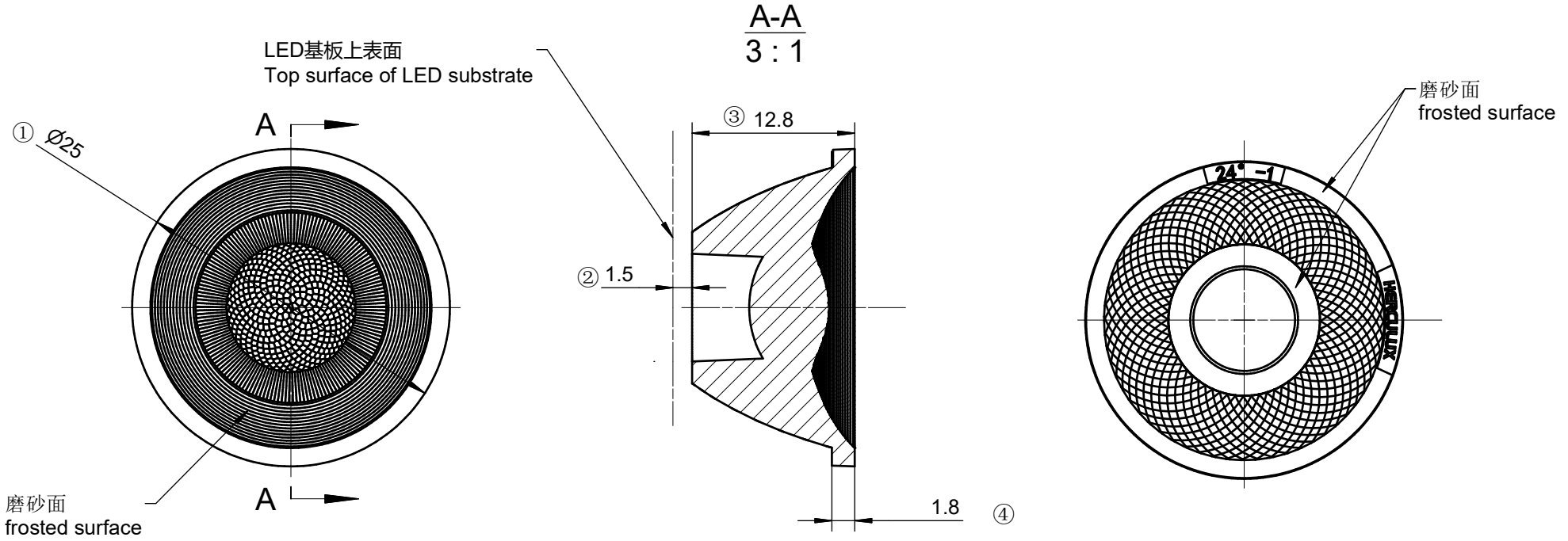

技术要求:
 1、未注圆角及拔模斜度按3D图。
 2、未注尺寸公差按右表。
 3、表面无飞边，缩水，气泡等缺陷。
 *4、灯具采用胶圈防水时：要求散热器与胶圈的接触面的粗糙度：Ra<3.2µm

Technical remark:
 1.Fillet and inclination not indicated according to 3D drawing.
 2. Dimensional tolerances not indicated are shown in the right list.
 3. The surface has no flash, shrinkage, bubbles and other defects.
 *4. When the lamp adopts rubber ring for waterproofing: the roughness of the contact surface between the radiator and the rubber ring is required: Ra<3.2µm

公差表MT5(mm)	
基本尺寸范围	公差值
Basic size	Tolerance value
<3	±0.1
3~10	±0.15
10~24	±0.20
24~65	±0.35
65~140	±0.50
140~250	±0.80
250~450	±1.2
>450	±2.0

2					4				
1					3				
序号 Item	更改标记 Change mark	更改内容 Change content	更改日期 Change date	签名 Signature	序号 Item	更改标记 Change mark	更改内容 Change content	更改日期 Change date	签名 Signature
光学设计 Optical design					Title:		Drawing No.		
结构设计 Structural design					HK 黑光25@13-24度透镜		HK-HG-25@13-24-D4-21-1g-1		
审核 Verify					HK Dark 25@13-24° lens		Part No. 1.01.92022		
审定 Approval					材料 Material:	PMMA	CDHK		

6 5 4 3 2 1

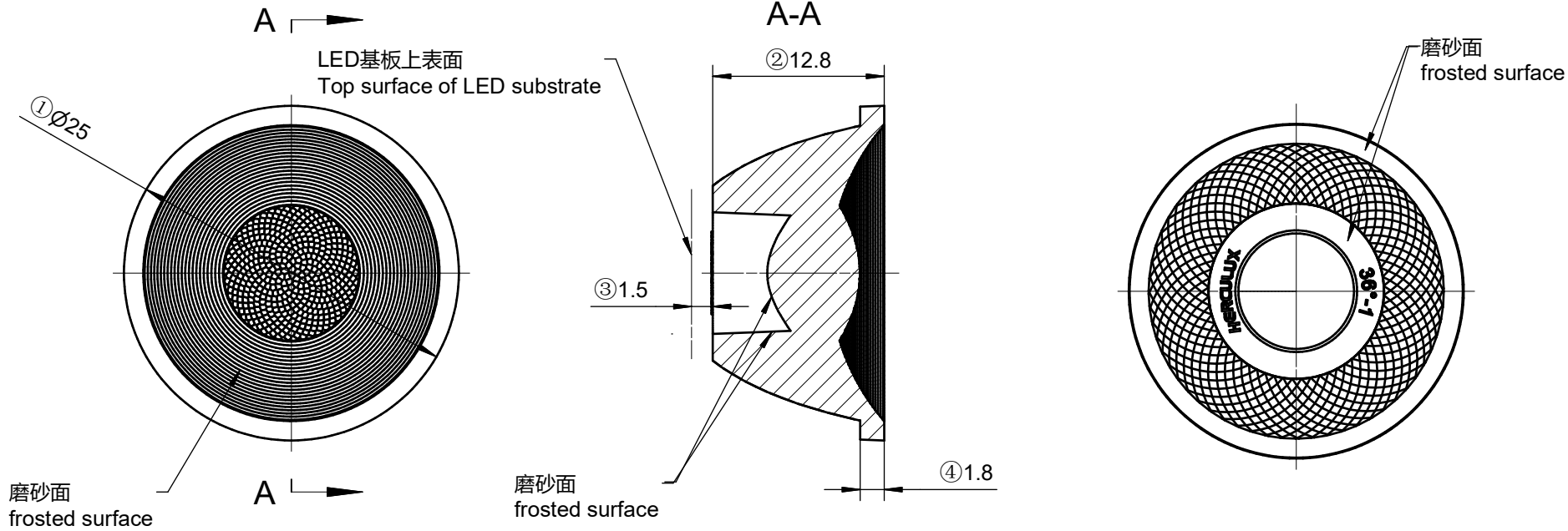

公差表MT5(mm)	
基本尺寸范围	公差值
Basic size	Tolerance value
<3	± 0.1
3~10	± 0.15
10~24	± 0.20
24~65	± 0.35
65~140	± 0.50
140~250	± 0.80
250~450	± 1.2
>450	± 2.0

技术要求：
 1、未注圆角及拔模斜度按3D图。
 2、未注尺寸公差按右表。
 3、表面无飞边，缩水，气泡等缺陷。
 *4、灯具采用胶圈防水时：要求散热器与胶圈的接触面的粗糙度： $Ra < 3.2\mu m$

Technical remark:
 1.Fillet and inclination not indicated according to 3D drawing.
 2. Dimensional tolerances not indicated are shown in the right list.
 3, The surface has no flash, shrinkage, bubbles and other defects.
 *4. When the lamp adopts rubber ring for waterproofing: the roughness of the contact surface between the radiator and the rubber ring is required: $Ra < 3.2\mu m$

2					4				
1					3				
序号 Item	更改标记 Change mark	更改内容 Change content	更改日期 Change date	签名 Signature	序号 Item	更改标记 Change mark	更改内容 Change content	更改日期 Change date	签名 Signature
光学设计 Optical design			Title:		Drawing No.		HK-HG-25@13-36-D4-21-1g-1		
结构设计 Structural design			HK 黑光25@13-36度透镜		Part No.		1.01.92065		
审核 Verify			HK Dark 25@13-36° lens		材料 Material:		PMMA		
审定 Approval							CDHK		

